

SPECIFICATIONS

| | |
|-----------------------|--|
| Frequency Range: | 2000~6000 MHz |
| Impedance | 50Ω |
| VSWR | 1.3 max. |
| Insertion Loss | 1.2dB max. |
| Isolation | 70dB min. / 80dB typ. |
| Switch type | Absorptive, SP2T |
| Switching Time | 100nS |
| RF Input Power(CW) | 0.2 Watts |
| Supply Voltage | ±5V |
| Current | 30mA |
| Operating Temp. | -40°C~+70°C |
| TTL Control Connector | Solder Pin [0-on, 1-off] |
| Connector Type | Field Replaceable SMA Female (0.38mm Pin) |

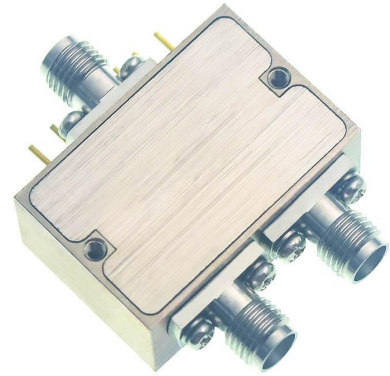

50 Ohm Typical Characteristics

| Frequency | VSWR (S00) | VSWR (S11) | IL (S01) | Phase (S02) | Isolation (S12) |
|-----------|------------|------------|----------|-------------|-----------------|
| MHz | :1 | :1 | dB | Deg. | dB |
| 1429 | 1.25 | 1.25 | -0.68 | -0.53 | -87.33 |
| 1857 | 1.21 | 1.21 | -0.72 | -0.69 | -87.42 |
| 2286 | 1.16 | 1.17 | -0.72 | -0.91 | -88.12 |
| 2714 | 1.11 | 1.15 | -0.77 | -1.09 | -88.53 |
| 3143 | 1.07 | 1.13 | -0.82 | -1.18 | -87.80 |
| 3571 | 1.06 | 1.13 | -0.84 | -1.3 | -86.61 |
| 4000 | 1.09 | 1.15 | -0.89 | -1.47 | -87.92 |
| 4429 | 1.12 | 1.17 | -0.97 | -1.64 | -87.69 |
| 4857 | 1.13 | 1.19 | -1.02 | -1.86 | -86.22 |
| 5286 | 1.12 | 1.19 | -1.03 | -2.01 | -87.98 |
| 5714 | 1.12 | 1.19 | -1.06 | -2.04 | -85.67 |
| 6143 | 1.11 | 1.17 | -1.10 | -2.3 | -88.06 |
| 6571 | 1.12 | 1.15 | -1.14 | -2.51 | -86.87 |
| 7000 | 1.14 | 1.11 | -1.21 | -2.86 | -84.84 |

Dimensions[mm]

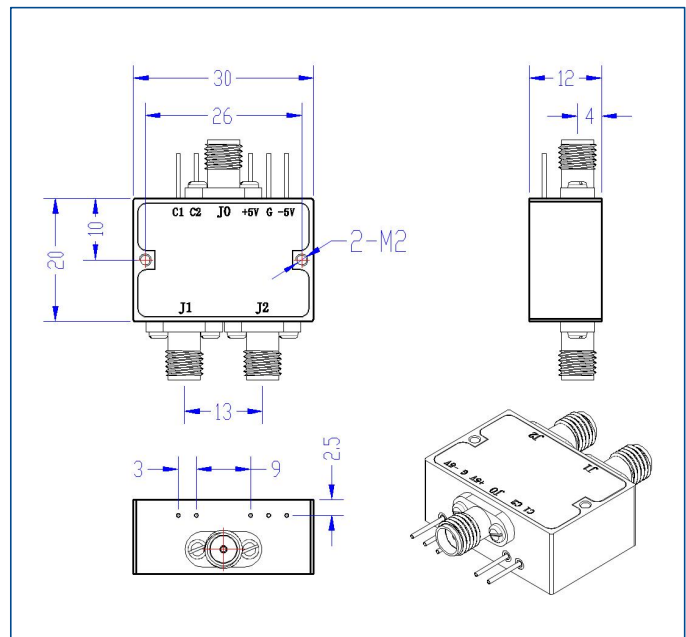

Typical Test Curve

