

TMLA-02002000-2825-50 2-20 GHz, 28dB, P1dB 25dBm, N.F. 5.0dB

FEATURES

- ❖ Wide Band Operation 2-20 GHz
- ❖ Small Signal Gain 29dB Typical
- ❖ P1dB Output Power +26dBm Typical
- ❖ Supply Voltage +12V@300mA

APPLICATIONS

- ❖ Wireless Infrastructure
- ❖ 5G Communication
- ❖ Test and Measurement Instrument

SPECIFICATIONS

Parameters	Min.	Typ.	Max.	Min.	Typ.	Max.	Units
Frequency Range	2	-	8	8	-	20	GHz
Impedance	-	50	-	-	50	-	Ohms
Gain	28	30	-	28	29.5	-	dB
Gain Flatness	-	±0.8	±1.0	-	±0.8	±1.0	dB
Gain Variation Over Temperature(-40°C~+85°C)	-	±1.0	-	-	±1.0	-	dB
Noise Figure	-	2.5	4.8	-	3.0	5.0	dB
Input VSWR	-	1.5	1.8	-	1.5	1.8	:1
Output VSWR	-	1.5	1.8	-	1.5	1.8	:1
Output 1dB Compression Point(P1dB)	25	26	-	21	23	-	dBm
Saturated Output Power(Psat)	-	28	-	-	27	-	dBm
Output 3rd Order Intercept(OIP3)	-	34	-	-	32	-	dBm
Supply Current(Vcc=+12V)	-	350	450	-	350	450	mA
Operating Temperature	-40°C~+85°C						
Storage Temperature	-50°C~+105°C						
Input/Output Connectors	SMA female						
Weight	90g max						
Surface Finishing	Gold Plated						
Material	Copper						

Outline Drawing [mm[inch]]

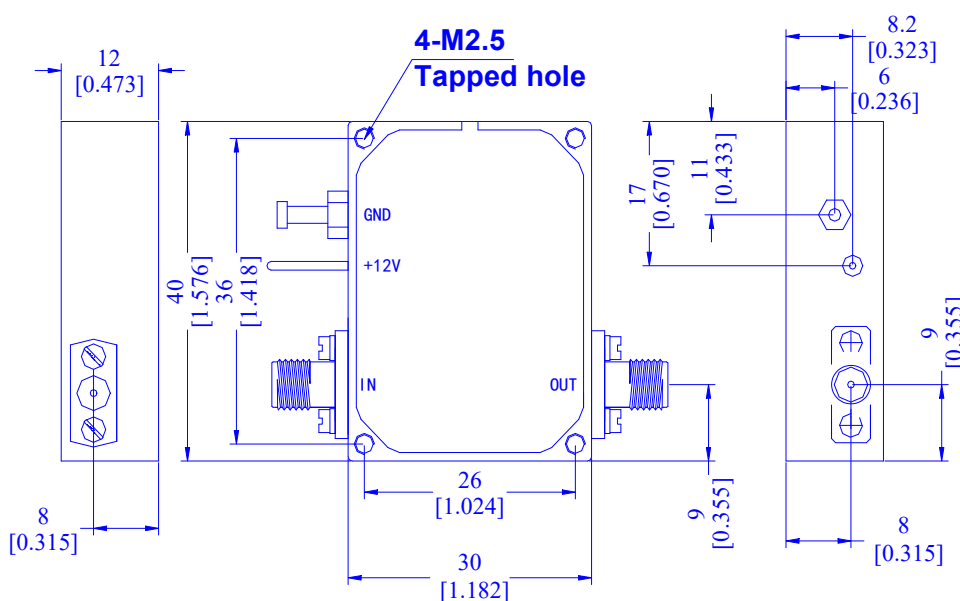

Tolerances ±0.1[0.004]

Absolute Maximum Ratings

Operating Voltage	+15V
RF Input Power	+5dBm

Note: *Heatsink required when operation, sell separately.*