

REV	DESCRIPTION OF REVISION	By	DATE	APPROVED
A	INITIAL RELEASE	C. Dai	2022/7/11	C. Chen

## TECHNICAL DATA

### ► Electrical Data

Frequency Range	0.01-18GHz
Low Level Sensitivity	≥0.5mV/μW
VSWR	≤1.8
Maximum Input Power	100mW(20dBm)
Maximum Flatness	±0.6dB
Impedance	50 Ohms

### ► Mechanical Data

Input Connector	N-Male
Output Connector	N-Female
Body	Nickel Plated Brass
Outer Conductor	Nickel Plated Brass
Inner Conductor(male)	Gold Plated Brass
Inner Conductor(female)	Gold plated beryllium copper

### ► Environmental Data

Operating Temperature	-20℃~+55℃
Storage Temperature	-45℃~+85℃

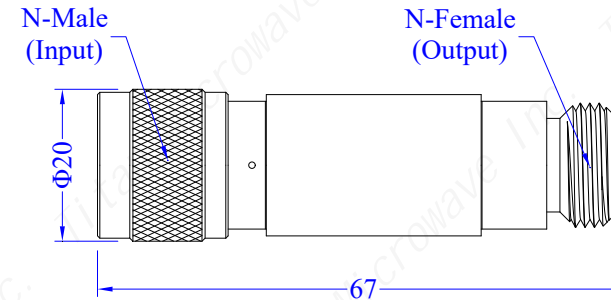

★ Negative output polarity standard. Add "P" to end of model number for positive output polarity.

#### Notes:

- ALL SPECIFICATIONS ARE SUBJECT TO CHANGE WITHOUT NOTICE AT ANY TIME
- CUSTOMER OUTLINE DRAWING FOR REFERENCE ONLY

DRAWN: L. Ma 11/07/22		
ENGINEER: J. Zhu 11/07/22		
APPROVED: C. Chen 11/07/22		
TOLERANCE UNLESS OTHERWISE SPECIFIED		
x	±0.50	[0.019"]
.x	±0.20	[0.008"]
.xx	±0.10	[0.004"]
ANGLES	±1°	

**TITLE:**  
Coaxial Detector, 0.01-18GHz, N-Male to N-Female, VSWR 1.8 max, Negative Polarity

**PART No.:**  
TMDT-0118-N



[www.titan-microwave.com](http://www.titan-microwave.com)



DIMENSIONS IN MILLIMETERS(mm)

<b>SIZE:</b> A4	<b>SCALE:</b>	<b>SHEET:</b> 1/1	<b>REV:</b> A
--------------------	---------------	----------------------	------------------