

TMPD4-02004000-20KA

2 to 40 GHz, 20W, 2.92mm-Female
4-WAY POWER DIVIDER

Electrical Characteristics

Frequency Range	2~40GHz
Insertion Loss	3.0dB max
(excluding theoretical loss 6.0dB)	
Amplitude Balance	±0.5dB
Phase Balance	±10°
VSWR(input port)	1.28:1 typ, 2.1:1 max
VSWR(output ports)	1.26:1 typ, 1.6:1 max
Isolation	15dB min, 20dB typ
Impedance	50 Ohms
Power Handling	20W(as a splitter)
.....	1W(as a combiner)

Outline Drawing(mm[inch])

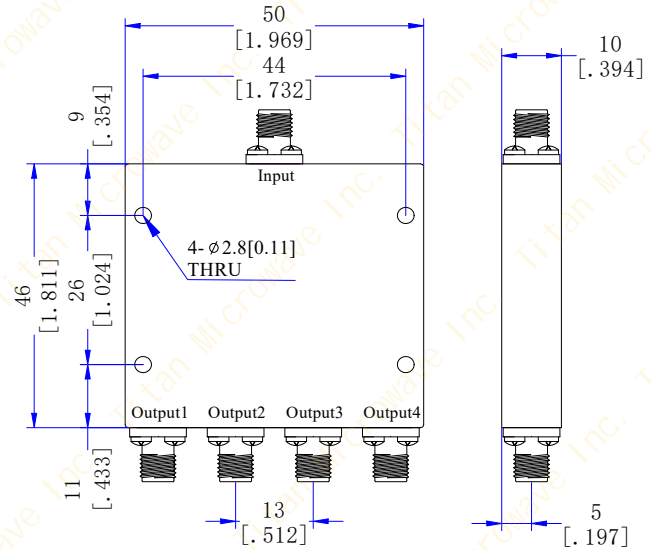

Mechanical & Environmental Characteristics

Dimensions	50 × 46 × 10mm
RF Connectors	2.92mm-Female
Surface Finishing	Black/Blue/Gray Paint
Operating Temperature	-40°C~+85°C
Storage Temperature	-50°C~+105°C
Weight	120g