

REV	DESCRIPTION OF REVISION	By	DATE	APPROVED
A	INITIAL RELEASE	C. Cai	2022/6/3	C. Chen

TECHNICAL DATA

► Electrical Characteristic

Frequency Range	DC~18GHz
Impedance	50 Ohms
VSWR	1.2 max
Insertion Loss	0.1√f(GHz)dB max
Dielectric Withstand Voltage	2000Vrms
Contact Resistance	Center Contact: 1mΩ max Outer Contact: 0.3mΩ max
Insulation Resistance	5000MΩ min
Mating Cycles	500 min

► Material & Finishing

Center Conductor	Beryllium Copper, Gold Plated
Outer Conductor	Passivated Stainless Steel
Insulators	PEI
Gasket	Silicone Rubber

► Mechanical

Force to Engage/Disengage	0.23Nm max
Recommended Mating Torque	0.79Nm~1.13Nm

► Environmental

Vibration	Method 204, test condition D
Shock	Method 213, test condition I
Thermal Shock	Method 107, test condition B
Corrosion (Salt Spray)	Method 101, test condition B
Moisture Resistance	Method 106, Insulation Resistance≥200MΩ

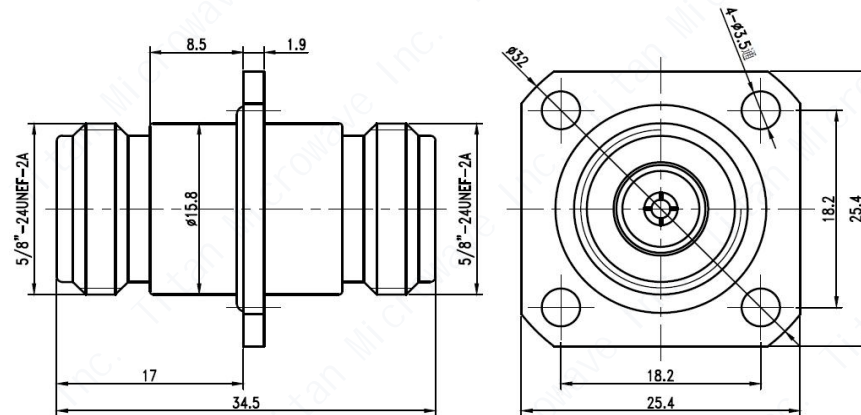

Notes:

- ALL SPECIFICATIONS ARE SUBJECT TO CHANGE WITHOUT NOTICE AT ANY TIME
- CUSTOMER OUTLINE DRAWING FOR REFERENCE ONLY

DRAWN: L. Ma 03/06/22		
ENGINEER: J. Zhu 03/06/22		
APPROVED: C. Chen 03/06/22		
TOLERANCE UNLESS OTHERWISE SPECIFIED		
x	±0.50	[0.019"]
.x	±0.20	[0.008"]
.xx	±0.10	[0.004"]
ANGLES	±1°	

TITLE:

Coaxial Adapter,
N-Female to N-Female,
4 Hole Flange Mount,
DC~18GHz

PART No.:

TMCALNFNFB



DIMENSIONS IN MILLIMETERS(mm)

SIZE: A4	SCALE:	SHEET: 1/1	REV: A
-------------	--------	---------------	-----------