

REV	DESCRIPTION OF REVISION	By	DATE	APPROVED
A	INITIAL RELEASE	C. Cai	2022/4/12	C. Chen

## TECHNICAL DATA

### ► Electrical Characteristic

Frequency Range	DC~18GHz
Impedance	50 Ohms
VSWR	1.15 max
Insertion Loss	0.04√f(GHz)dB max
Dielectric Withstand Voltage	1000Vrms
Contact Resistance	Center Contact: 3mΩ max Outer Contact: 2.5mΩ max
Insulation Resistance	5000MΩ min
Mating Cycles	500 min

### ► Material & Finishing

Center Conductor	Beryllium Copper, Gold Plating
Outer Conductor	Passivated Stainless Steel
Insulators	PTFE & PEI

### ► Mechanical

Force to Engage/Disengage	0.23Nm max
Recommended Mating Torque	0.79Nm~1.13Nm

### ► Environmental

Vibration	Method 204, test condition D
Shock	Method 213, test condition I
Thermal Shock	Method 107, test condition B
Corrosion (Salt Spray)	Method 101, test condition B
Moisture Resistance	Method 106, Insulation Resistance≥200MΩ

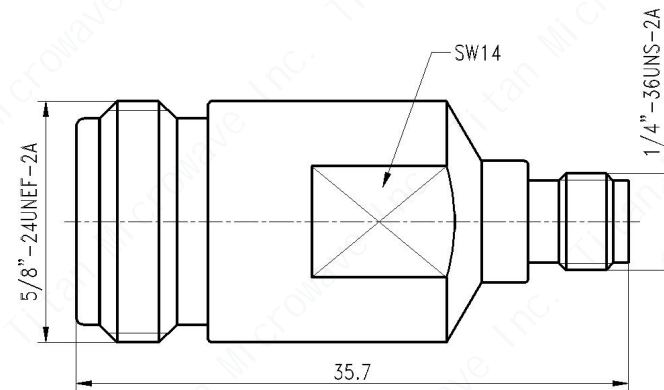

DRAWN: L. Ma 12/04/22		
ENGINEER: J. Zhu 12/04/22		
APPROVED: C. Chen 12/04/22		
TOLERANCE UNLESS OTHERWISE SPECIFIED		
x	±0.50	[0.019"]
.x	±0.20	[0.008"]
.xx	±0.10	[0.004"]
ANGLES	±1°	

**TITLE:**  
Coaxial Adapter,  
N-Female to SMA-Female,  
Straight, DC~18GHz

**PART No.:**  
TMCANFSF-A

**成都巨人微波**  
**TITAN MICROWAVE INC.**  
- A Professional RF & Microwave Components Supplier -

[www.titan-microwave.com](http://www.titan-microwave.com)



DIMENSIONS IN MILLIMETERS(mm)

<b>SIZE:</b> A4	<b>SCALE:</b>	<b>SHEET:</b> 1/1	<b>REV:</b> A
--------------------	---------------	----------------------	------------------

**Notes:**

- ALL SPECIFICATIONS ARE SUBJECT TO CHANGE WITHOUT NOTICE AT ANY TIME
- CUSTOMER OUTLINE DRAWING FOR REFERENCE ONLY