

REV	DESCRIPTION OF REVISION	By	DATE	APPROVED
A	INITIAL RELEASE	C. Cai	2022/3/26	C. Chen

TECHNICAL DATA

► Electrical Characteristic

Frequency Range	DC~50GHz
Impedance	50 Ohms
VSWR	1.25 max
Insertion Loss	0.08√f(GHz)dB max
Dielectric Withstand Voltage	200Vrms
Contact Resistance	Center Contact: 4mΩ max Outer Contact: 2.5mΩ max
Insulation Resistance	5000MΩ min
Mating Cycles	500 min

► Material & Finishing

Center Conductor	Beryllium Copper, Gold Plating
Outer Conductor	Passivated Stainless Steel
Insulators	PEI

► Mechanical

Force to Engage/Disengage	2.4mm: 0.8Nm max, 1.0mm: 0.6Nm max
Recommended Mating Torque	2.4mm: 0.8Nm~1.1Nm 1.0mm: 0.3Nm~0.41Nm

► Environmental

Vibration	Method 204, Test Condition D
Shock	Method 213, Test Condition I
Thermal Shock	Method 107, Test Condition B
Corrosion (Salt Spray)	Method 101, Test Condition B
Moisture Resistance	Method 106, Insulation Resistance≥200MΩ

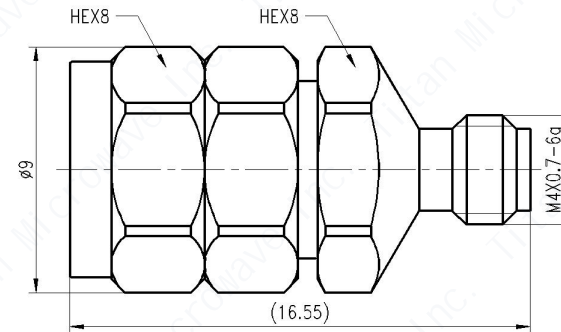

Notes:

- ALL SPECIFICATIONS ARE SUBJECT TO CHANGE WITHOUT NOTICE AT ANY TIME
- CUSTOMER OUTLINE DRAWING FOR REFERENCE ONLY

DRAWN: L. Ma 26/03/22		
ENGINEER: J. Zhu 26/03/22		
APPROVED: C. Chen 26/03/22		
TOLERANCE UNLESS OTHERWISE SPECIFIED		
x	±0.50	[0.019"]
.x	±0.20	[0.008"]
.xx	±0.10	[0.004"]
ANGLES	±1°	

TITLE:

Coaxial Adapter,
1.0mm-Female to
2.4mm-Male, Straight,
DC~50GHz

PART No.:

TMCA01FW



DIMENSIONS IN MILLIMETERS(mm)

SIZE: A4	SCALE:	SHEET: 1/1	REV: A
-------------	--------	---------------	-----------