

REV	DESCRIPTION OF REVISION	By	DATE	APPROVED
A	INITIAL RELEASE	C. Cai	2022/3/26	C. Chen

TECHNICAL DATA

► Electrical Characteristic

Frequency Range	DC~50GHz
Impedance	50 Ohms
VSWR	1.2 max
Insertion Loss	0.05√f(GHz)dB max
Dielectric Withstand Voltage	750Vrms
Contact Resistance	Center Contact: 4mΩ max Outer Contact: 2.5mΩ max
Insulation Resistance	5000MΩ min
Mating Cycles	500 min

► Material & Finishing

Center Conductor	Gold Plated Beryllium Copper
Outer Conductor	Passivated Stainless Steel
Insulators	PEI

► Mechanical

Force to Engage/Disengage	0.8Nm max
Recommended Mating Torque	0.8Nm~1.1Nm

► Environmental

Vibration	Method 204, Test Condition D
Shock	Method 213, Test Condition I
Thermal Shock	Method 107, Test Condition B
Corrosion (Salt Spray)	Method 101, Test Condition B
Moisture Resistance	Method 106, Insulation Resistance≥200MΩ

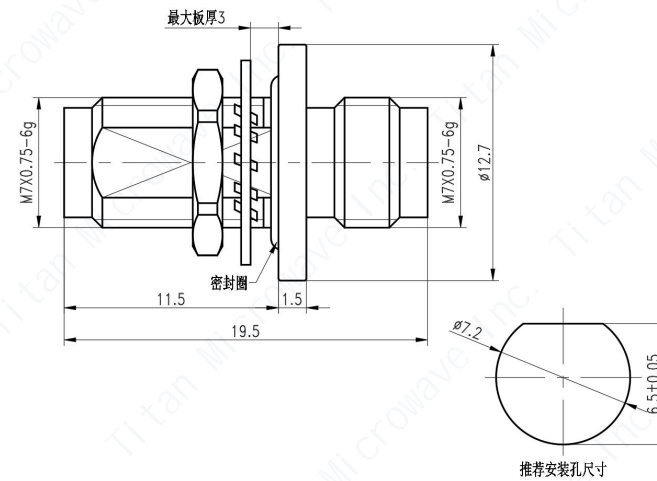

DRAWN: L. Ma 26/03/22		
ENGINEER: J. Zhu 26/03/22		
APPROVED: C. Chen 26/03/22		
TOLERANCE UNLESS OTHERWISE SPECIFIED		
x	±0.50	[0.019"]
.x	±0.20	[0.008"]
.xx	±0.10	[0.004"]
ANGLES	±1°	

TITLE:	Coaxial Adapter, 2.4mm-Female to 2.4mm-Female, Bulkhead, DC~50GHz
PART No.:	TMCABHWFWF



DIMENSIONS IN MILLIMETERS(mm)

SIZE:	SCALE:	SHEET:	REV:
A4		1/1	A

Notes:

- ALL SPECIFICATIONS ARE SUBJECT TO CHANGE WITHOUT NOTICE AT ANY TIME
- CUSTOMER OUTLINE DRAWING FOR REFERENCE ONLY