

REV	DESCRIPTION OF REVISION	By	DATE	APPROVED
A	INITIAL RELEASE	C. Cai	2022/3/26	C. Chen

## TECHNICAL DATA

### ► Electrical Characteristic

Frequency Range	DC~18GHz
Impedance	50 Ohms
VSWR	1.3 max
Insertion Loss	0.1√f(GHz)dB max
Dielectric Withstand Voltage	2000Vrms
Contact Resistance	Center Contact: 3mΩ max Outer Contact: 5mΩ max
Insulation Resistance	5000MΩ min
Mating Cycles	500 min

### ► Material & Finishing

Center Conductor	Gold Plated Brass & Gold Plated Beryllium Copper
Outer Conductor	Stainless Steel, Passivated
Insulators	PEI & PTFE

### ► Mechanical

Force to Engage/Disengage	0.23Nm max
Recommended Mating Torque	N: 0.79Nm~1.13Nm; TNCA: 0.45Nm~0.68Nm

### ► Environmental

Vibration	Method 204, Test Condition D
Shock	Method 213, Test Condition I
Thermal Shock	Method 107, Test Condition B
Corrosion (Salt Spray)	Method 101, Test Condition B
Moisture Resistance	Method 106, Insulation Resistance≥200MΩ

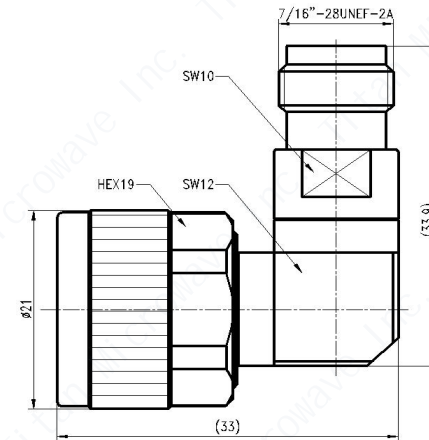

DRAWN: L. Ma 26/03/22		
ENGINEER: J. Zhu 26/03/22		
APPROVED: C. Chen 26/03/22		
TOLERANCE UNLESS OTHERWISE SPECIFIED		
x	±0.50	[0.019"]
.x	±0.20	[0.008"]
.xx	±0.10	[0.004"]
ANGLES	±1°	

TITLE:  
Coaxial Adapter,  
N-Male to TNCA-Female,  
Right Angle, DC~18GHz

PART No.:  
TMCARANGF



DIMENSIONS IN MILLIMETERS(mm)

SIZE: A4	SCALE:	SHEET: 1/1	REV: A
-------------	--------	---------------	-----------

#### Notes:

- ALL SPECIFICATIONS ARE SUBJECT TO CHANGE WITHOUT NOTICE AT ANY TIME
- CUSTOMER OUTLINE DRAWING FOR REFERENCE ONLY