

| REV | DESCRIPTION OF REVISION | By     | DATE      | APPROVED |
|-----|-------------------------|--------|-----------|----------|
| A   | INITIAL RELEASE         | C. Cai | 2022/3/26 | C. Chen  |

## TECHNICAL DATA

### ► Electrical Characteristic

|                              |   |
|------------------------------|---|
| Frequency Range              | DC~18GHz  |
| Impedance                    | 50 Ohms   |
| VSWR                         | 1.2 max   |
| Insertion Loss               | 0.06√f(GHz)dB max                                   |
| Dielectric Withstand Voltage | 500Vrms   |
| Contact Resistance           | Center Contact: 6mΩ max<br>Outer Contact: 2.5mΩ max |
| Insulation Resistance        | 5000MΩ min  |
| Mating Cycles                | SMA: 500 min, SSMP: 100 min(full detent)            |

### ► Material & Finishing

|                  |  |
|------------------|--|
| Center Conductor | Beryllium Copper, Gold Plating                               |
| Outer Conductor  | Stainless Steel, Passivated & Beryllium Copper, Gold Plating |
| Insulators       | PEI & PTFE   |

### ► Mechanical

|                           |   |
|---------------------------|---|
| Force to Engage/Disengage | SMA: 0.23Nm max; SSMP: 20N~36N(full detent) |
| Recommended Mating Torque | SMA: 0.79Nm~1.13Nm                          |

### ► Environmental

|                        |   |
|------------------------|---|
| Vibration              | Method 204, Test Condition D            |
| Shock                  | Method 213, Test Condition I            |
| Thermal Shock          | Method 107, Test Condition B            |
| Corrosion (Salt Spray) | Method 101, Test Condition B            |
| Moisture Resistance    | Method 106, Insulation Resistance≥200MΩ |

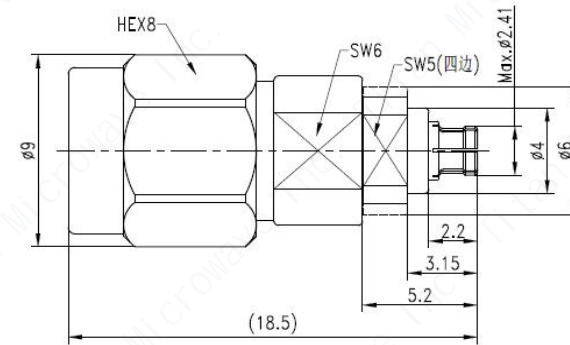

|                                      |       |          |
|--------------------------------------|-------|----------|
| DRAWN: L. Ma 26/03/22                |       |          |
| ENGINEER: J. Zhu 26/03/22            |       |          |
| APPROVED: C. Chen 26/03/22           |       |          |
| TOLERANCE UNLESS OTHERWISE SPECIFIED |       |          |
| x                                    | ±0.50 | [0.019"] |
| .x                                   | ±0.20 | [0.008"] |
| .xx                                  | ±0.10 | [0.004"] |
| ANGLES                               | ±1°   |          |

**TITLE:**  
Coaxial Adapter,  
SMA-Male to SSMP-  
Female, Straight,  
DC~18GHz

**PART No.:**  
TMCASXF



DIMENSIONS IN MILLIMETERS(mm)

|             |        |               |           |
|-------------|--------|---------------|-----------|
| SIZE:<br>A4 | SCALE: | SHEET:<br>1/1 | REV:<br>A |
|-------------|--------|---------------|-----------|

**Notes:**

- ALL SPECIFICATIONS ARE SUBJECT TO CHANGE WITHOUT NOTICE AT ANY TIME
- CUSTOMER OUTLINE DRAWING FOR REFERENCE ONLY